

Bennett Pump Company
Footprint Drawings Booklet for Horizon2 Series Remote Dispensers and Suction Pumps

April 2006

This booklet contains four (4) footprint drawings that cover all models of Horizon2 retail multi-product remote dispensers and suction pumps.

Drawing #P1190—All 2400 Series (48" wide) Horizon2 REMOTE Dispensers

Drawing #P1193—All 2400 Series (48" wide) Horizon2 SUCTION Pumps

Drawing #P1189—All 2300 Series (36" wide) Horizon2 REMOTE Dispensers

Drawing #P1192—All 2300 Series (36" wide) Horizon2 SUCTION Pumps

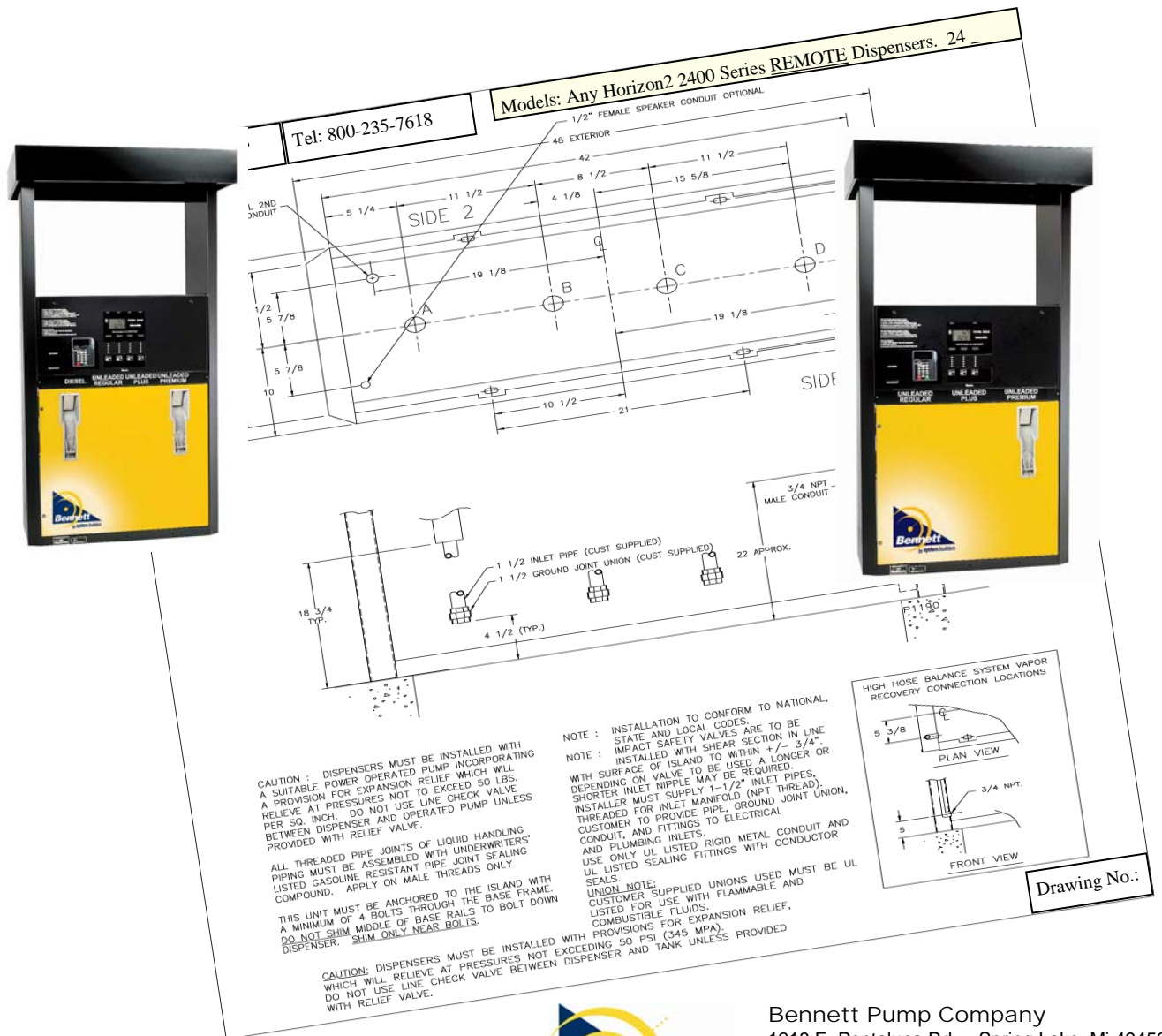

Drawing No.:



Bennett Pump Company
 1218 E. Pontaluna Rd. ~ Spring Lake, Mi 49456
 Tel: (800) 235-7618 ~ (231) 798-1310
 Fax: 231-799-6202
 sales@bennettpump.com
 www.bennettpump.com

BENNETT PUMP COMPANY
 1218 E. Pontaluna Rd.
 Spring Lake, Mi 49456

Tel: 800-235-7618
 Tel: 231-798-1310
 Fax: 231-799-6202

Models: Any Horizon2 2400 Series REMOTE Dispensers. 24 __FS__ HXR
 For Example: 2432FS-2HXR (the 10th digit "R" designates a REMOTE Dispenser.)

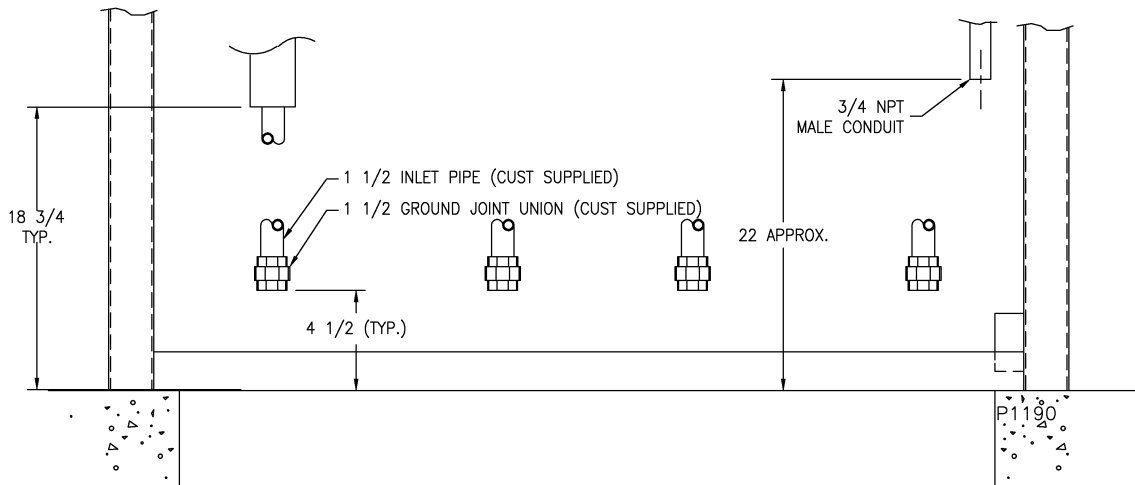
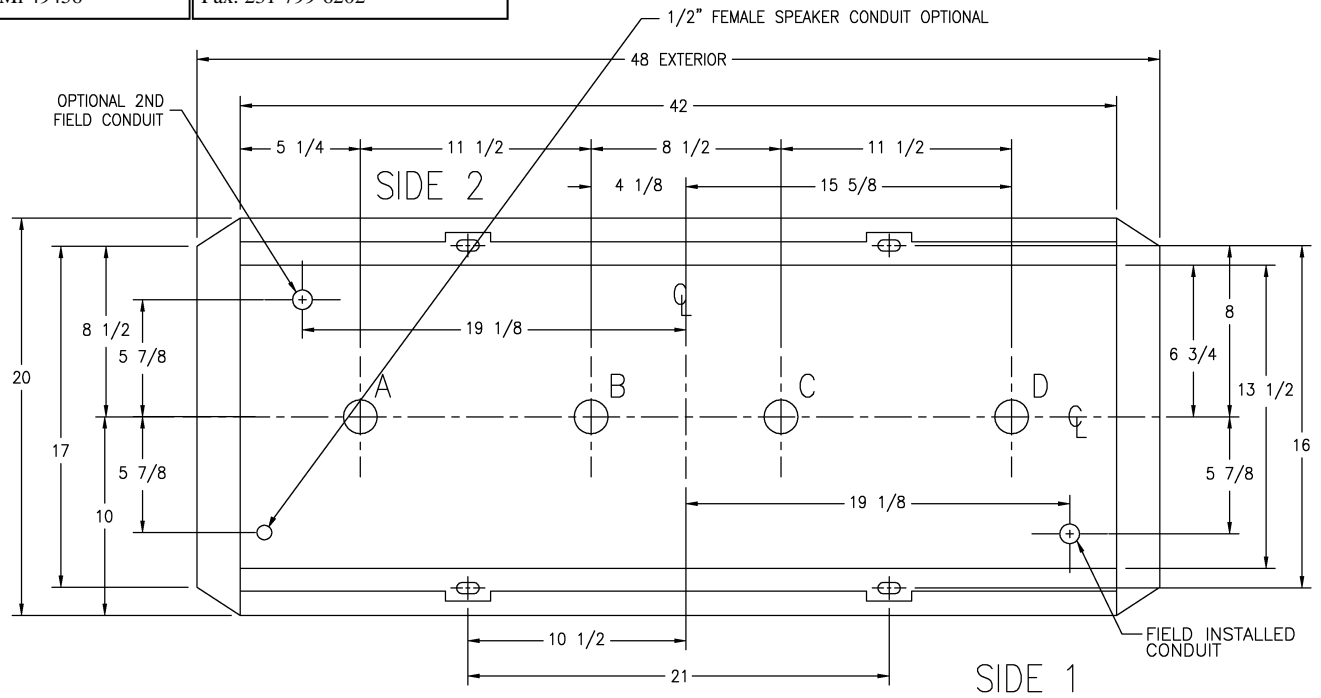

CAUTION : DISPENSERS MUST BE INSTALLED WITH A SUITABLE POWER OPERATED PUMP INCORPORATING A PROVISION FOR EXPANSION RELIEF WHICH WILL RELIEVE AT PRESSURES NOT TO EXCEED 50 LBS. PER SQ. INCH. DO NOT USE LINE CHECK VALVE BETWEEN DISPENSER AND OPERATED PUMP UNLESS PROVIDED WITH RELIEF VALVE.

ALL THREADED PIPE JOINTS OF LIQUID HANDLING PIPING MUST BE ASSEMBLED WITH UNDERWRITERS' LISTED GASOLINE RESISTANT PIPE JOINT SEALING COMPOUND. APPLY ON MALE THREADS ONLY.

THIS UNIT MUST BE ANCHORED TO THE ISLAND WITH A MINIMUM OF 4 BOLTS THROUGH THE BASE FRAME. DO NOT SHIM MIDDLE OF BASE RAILS TO BOLT DOWN DISPENSER. SHIM ONLY NEAR BOLTS.

NOTE : INSTALLATION TO CONFORM TO NATIONAL, STATE AND LOCAL CODES.

NOTE : IMPACT SAFETY VALVES ARE TO BE INSTALLED WITH SHEAR SECTION IN LINE WITH SURFACE OF ISLAND TO WITHIN +/- 3/4". DEPENDING ON VALVE TO BE USED A LONGER OR SHORTER INLET NIPPLE MAY BE REQUIRED. INSTALLER MUST SUPPLY 1-1/2" INLET PIPES, THREADED FOR INLET MANIFOLD (NPT THREAD). CUSTOMER TO PROVIDE PIPE, GROUND JOINT UNION, CONDUIT, AND FITTINGS TO ELECTRICAL AND PLUMBING INLETS. USE ONLY UL LISTED RIGID METAL CONDUIT AND UL LISTED SEALING FITTINGS WITH CONDUCTOR SEALS.

UNION NOTE: CUSTOMER SUPPLIED UNIONS USED MUST BE UL LISTED FOR USE WITH FLAMMABLE AND COMBUSTIBLE FLUIDS.

HIGH HOSE BALANCE SYSTEM VAPOR RECOVERY CONNECTION LOCATIONS

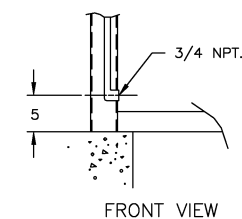
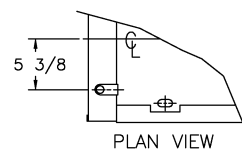

CAUTION: DISPENSERS MUST BE INSTALLED WITH PROVISIONS FOR EXPANSION RELIEF, WHICH WILL RELIEVE AT PRESSURES NOT EXCEEDING 50 PSI (345 MPA). DO NOT USE LINE CHECK VALVE BETWEEN DISPENSER AND TANK UNLESS PROVIDED WITH RELIEF VALVE.

Drawing No.: **P1190**
 Rev. Level: **B**
 Date: **02-16-06**

BENNETT PUMP COMPANY
 1218 E. Pontaluna Rd.
 Spring Lake, Mi 49456

Tel: 800-235-7618
 Tel: 231-798-1310
 Fax: 231-799-6202

Models: Any Horizon2 2400 Series SUCTION Pump. 24 _ _FS_ _HXS
 For Example: 2432FS-2HXS (the 10th digit "S" designates a SUCTION Pump.

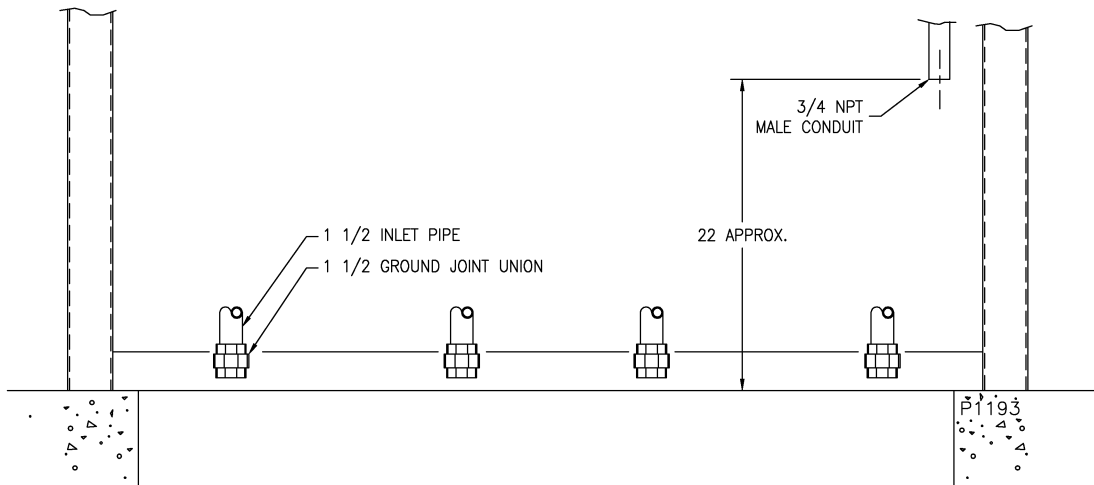
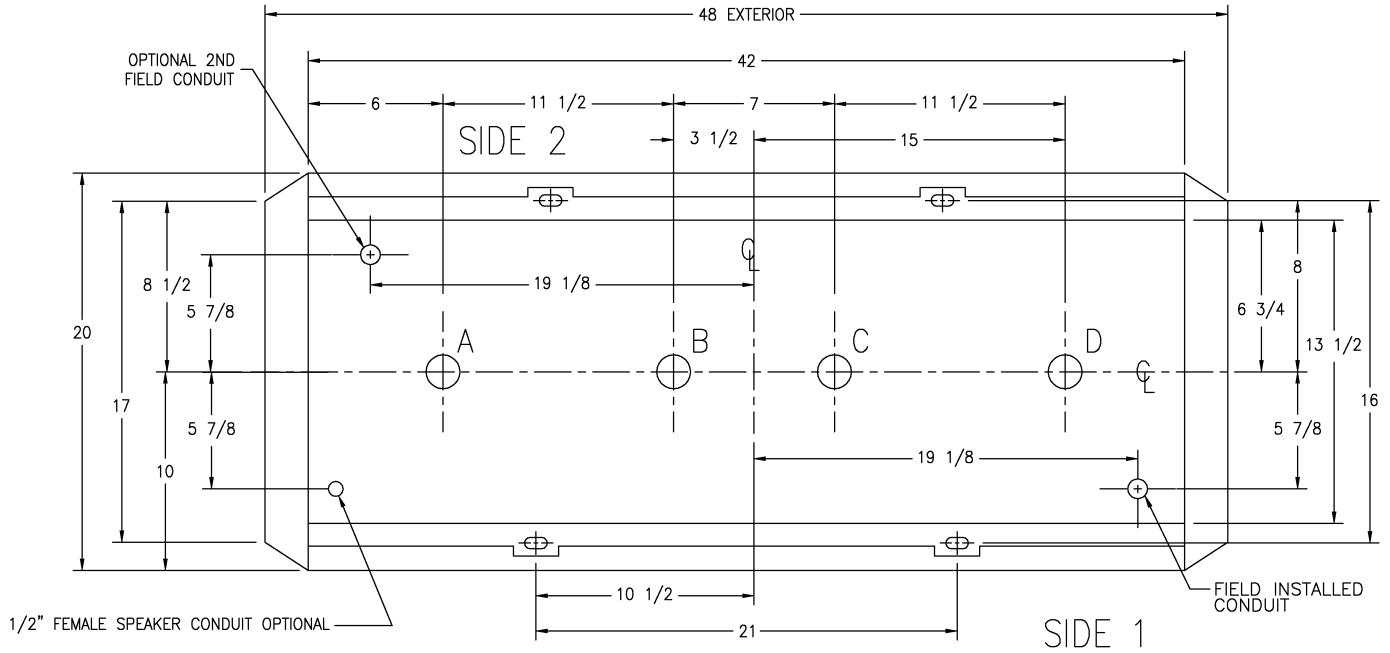

ALL THREADED PIPE JOINTS OF LIQUID HANDLING PIPING MUST BE ASSEMBLED WITH UNDERWRITERS' LISTED GASOLINE RESISTANT PIPE JOINT SEALING COMPOUND. APPLY ON MALE THREADS ONLY.

THIS UNIT MUST BE ANCHORED TO THE ISLAND WITH A MINIMUM OF 4 BOLTS THROUGH THE BASE FRAME. DO NOT SHIM MIDDLE OF BASE RAILS TO BOLT DOWN DISPENSER. SHIM ONLY NEAR BOLTS.

CAUTION: DISPENSERS MUST BE INSTALLED WITH PROVISIONS FOR EXPANSION RELIEF, WHICH WILL RELIEVE AT PRESSURES NOT TO EXCEED 50 PSI (345 MPA). DO NOT USE LINE CHECK VALVE BETWEEN DISPENSER AND TANK UNLESS PROVIDED WITH RELIEF VALVE.

NOTE : INSTALLATION TO CONFORM TO NATIONAL, STATE AND LOCAL CODES.

1-1/2" INLET PIPES, THREADED FOR GROUND JOINT UNION. CUSTOMER TO PROVIDE CONDUIT AND FITTINGS TO ELECTRICAL INLET.

USE ONLY UL LISTED RIGID METAL CONDUIT AND UL LISTED SEALING FITTINGS WITH CONDUCTOR SEALS.

UNION NOTE:

CUSTOMER SUPPLIED UNIONS USED MUST BE UL LISTED FOR USE WITH FLAMMABLE AND COMBUSTIBLE FLUIDS.

HIGH HOSE BALANCE SYSTEM VAPOR RECOVERY CONNECTION LOCATIONS

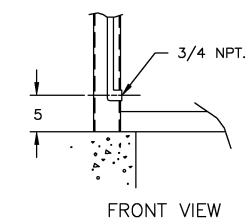
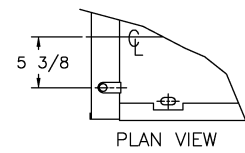

Drawing No.: **P1193**
 Rev. Level: **B**
 Date: **02-16-06**

BENNETT PUMP COMPANY
 1218 E. Pontaluna Rd.
 Spring Lake, Mi 49456

Tel: 800-235-7618
 Tel: 231-798-1310
 Fax: 231-799-6202

Models: Any Horizon2 2300 Series REMOTE Dispensers. 23 __FS__ HXR
 For Example: 2332FS-2HXR (the 10th digit "R" designates a REMOTE Dispenser.)

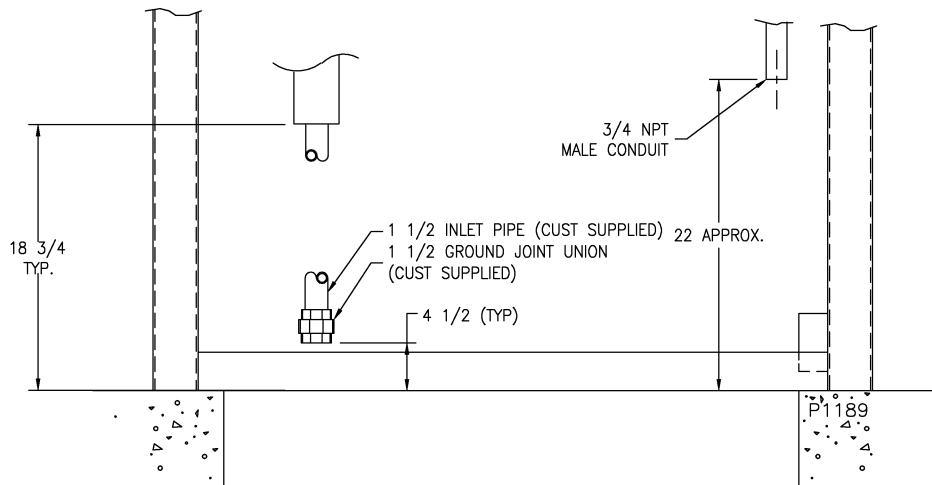
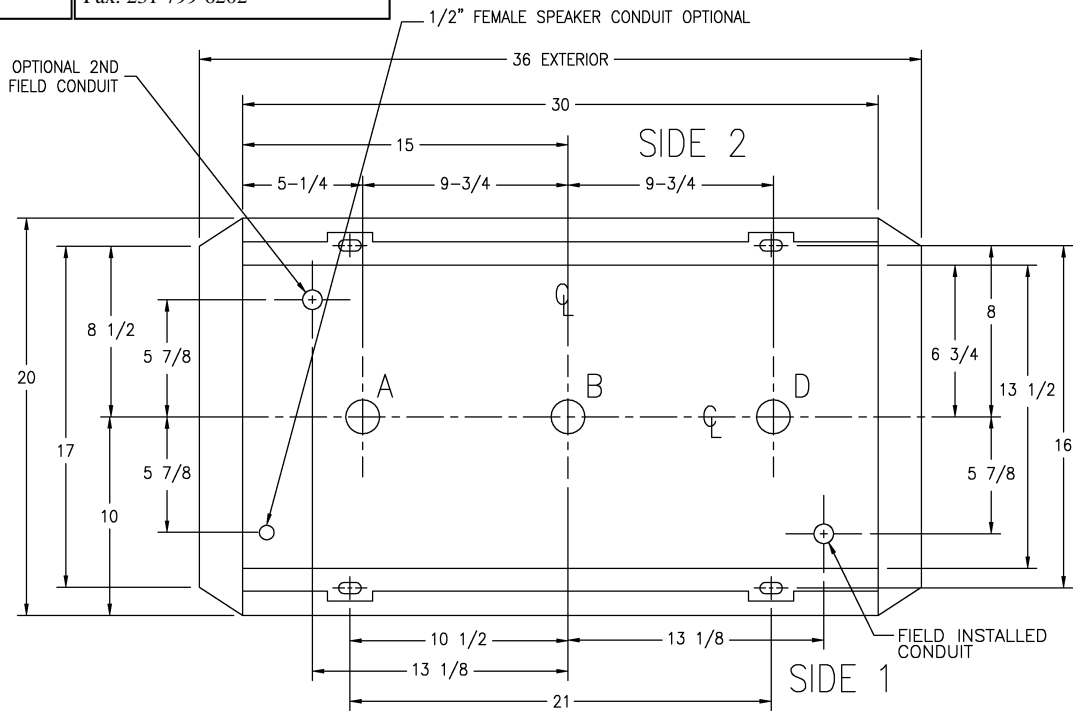

CAUTION : DISPENSERS MUST BE INSTALLED WITH A SUITABLE POWER OPERATED PUMP INCORPORATING A PROVISION FOR EXPANSION RELIEF WHICH WILL RELIEVE AT PRESSURES NOT TO EXCEED 50 LBS. PER SQ. INCH. DO NOT USE LINE CHECK VALVE BETWEEN DISPENSER AND OPERATED PUMP UNLESS PROVIDED WITH RELIEF VALVE.

ALL THREADED PIPE JOINTS OF LIQUID HANDLING PIPING MUST BE ASSEMBLED WITH UNDERWRITERS' LISTED GASOLINE RESISTANT PIPE JOINT SEALING COMPOUND. APPLY ON MALE THREADS ONLY.

THIS UNIT MUST BE ANCHORED TO THE ISLAND WITH A MINIMUM OF 4 BOLTS THROUGH THE BASE FRAME. DO NOT SHIM MIDDLE OF BASE RAILS TO BOLT DOWN DISPENSER. SHIM ONLY NEAR BOLTS.

NOTE : INSTALLATION TO CONFORM TO NATIONAL, STATE AND LOCAL CODES.

NOTE : IMPACT SAFETY VALVES ARE TO BE INSTALLED WITH SHEAR SECTION IN LINE WITH SURFACE OF ISLAND TO WITHIN +/- 3/4". DEPENDING ON VALVE TO BE USED A LONGER OR SHORTER INLET NIPPLE MAY BE REQUIRED. INSTALLER MUST SUPPLY 1-1/2" INLET PIPES, THREADED FOR INLET MANIFOLD (NPT THREAD). CUSTOMER TO PROVIDE PIPE, GROUND JOINT UNION, CONDUIT, AND FITTINGS TO ELECTRICAL AND PLUMBING INLETS. USE ONLY UL LISTED RIGID METAL CONDUIT AND UL LISTED SEALING FITTINGS WITH CONDUCTOR SEALS.

UNION NOTE: CUSTOMER SUPPLIED UNIONS USED MUST BE UL LISTED FOR USE WITH FLAMMABLE AND COMBUSTIBLE FLUIDS.

HIGH HOSE BALANCE SYSTEM VAPOR RECOVERY CONNECTION LOCATIONS

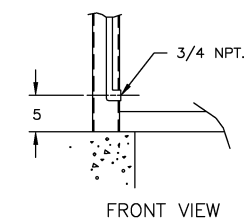
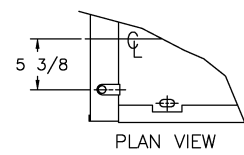

CAUTION: DISPENSERS MUST BE INSTALLED WITH PROVISIONS FOR EXPANSION RELIEF, WHICH WILL RELIEVE AT PRESSURES NOT TO EXCEED 50 PSI (345 MPA). DO NOT USE LINE CHECK VALVE BETWEEN DISPENSER AND TANK UNLESS PROVIDED WITH RELIEF VALVE.

Drawing No: **P1189**
 Rev. Level: **B**
 Date: **02-16-06**

BENNETT PUMP COMPANY
 1218 E. Pontaluna Rd.
 Spring Lake, Mi 49456

Tel: 800-235-7618
 Tel: 231-798-1310
 Fax: 231-799-6202

Models: Any Horizon2 2300 Series SUCTION Pump. 23 _ _FS_ _HXS
 For Example: 2332FS-2HXS (the 10th digit "S" designates a SUCTION Pump.

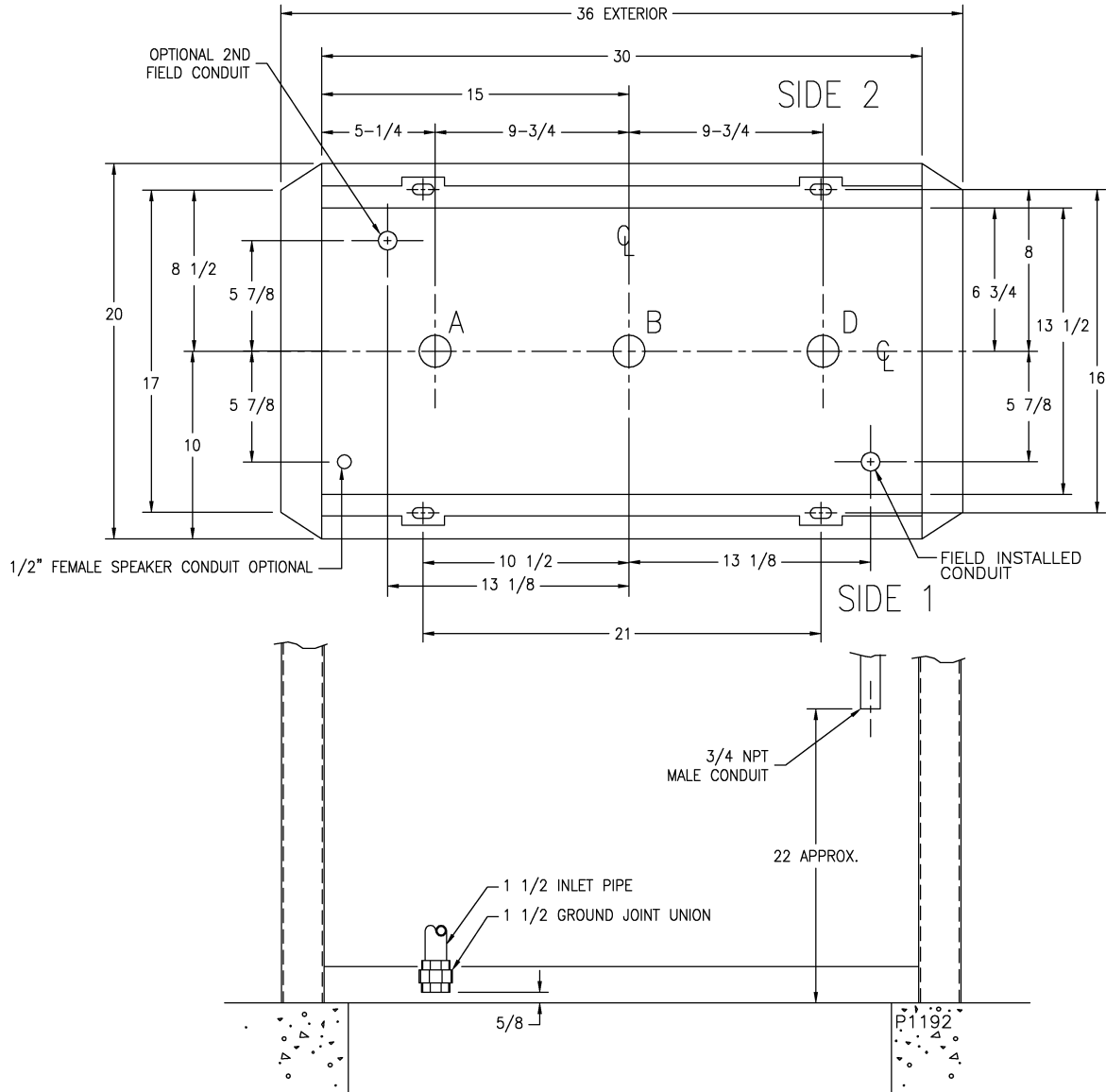

ALL THREADED PIPE JOINTS OF LIQUID HANDLING PIPING MUST BE ASSEMBLED WITH UNDERWRITERS' LISTED GASOLINE RESISTANT PIPE JOINT SEALING COMPOUND. APPLY ON MALE THREADS ONLY.

THIS UNIT MUST BE ANCHORED TO THE ISLAND WITH A MINIMUM OF 4 BOLTS THROUGH THE BASE FRAME. DO NOT SHIM MIDDLE OF BASE RAILS TO BOLT DOWN DISPENSER. SHIM ONLY NEAR BOLTS.

CAUTION: DISPENSERS MUST BE INSTALLED WITH PROVISIONS FOR EXPANSION RELIEF, WHICH WILL RELIEVE AT PRESSURES NOT TO EXCEED 50 PSI (345 MPA). DO NOT USE LINE CHECK VALVE BETWEEN DISPENSER AND TANK UNLESS PROVIDED WITH RELIEF VALVE.

NOTE : INSTALLATION TO CONFORM TO NATIONAL, STATE AND LOCAL CODES.
 1-1/2" INLET PIPES, THREADED FOR GROUND JOINT UNION.
 CUSTOMER TO PROVIDE CONDUIT AND FITTINGS TO ELECTRICAL INLET.
 USE ONLY UL LISTED RIGID METAL CONDUIT AND UL LISTED SEALING FITTINGS WITH CONDUCTOR SEALS.
 UNION NOTE:
 CUSTOMER SUPPLIED UNIONS USED MUST BE UL LISTED FOR USE WITH FLAMMABLE AND COMBUSTIBLE FLUIDS.

HIGH HOSE BALANCE SYSTEM VAPOR RECOVERY CONNECTION LOCATIONS

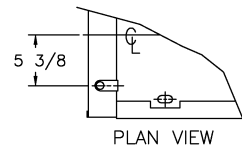

PLAN VIEW

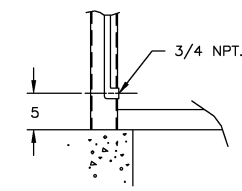

FRONT VIEW

Drawing No.: **P1192**
 Rev. Level: **B**
 Date: **02-16-06**