

# WIRING - FACTORY and INSTALLATION

Models R12X, R22X, & R24X Retail Series  
 Models C12X, C22X, & C24X Commercial Series  
 Single and One or Two Product Twin  
 Remote Dispenser with MI-350 Interface  
 Refer to Owners Manual for Optional Interface Methods

**WARNING:** When connecting to a mechanical pump console or fleet system as shown in this diagram, jumpers MUST re-positioned on the dispenser's PS/IO board BEFORE applied AC power is applied. Failure to move jumpers will cause damage to the dispenser's electronics. Please see installation manual for jumper information.

### NOTES:

- All wiring must be installed in accordance with National Electrical Code (NFPA #70), automotive and marine service station code (NFPA #30A), and all state and local codes.
- Pull a green 12 AWG or larger ground wire and secure to the ground screw in the dispenser junction box. Do not rely on metal conduit as ground. Each dispenser junction box and interconnection box chassis must be within 1 ohm of earth ground.
- All specified wiring gauge is minimum. Use only stranded wire with THHN insulation. Do not reuse old wire.
- Do not use PVC conduit. Use only rigid metal conduit.
- Dispenser power (CB-1, 2 & 3) must be a dedicated circuit. A maximum of five (5) dispensers may be placed on one (1) dispenser power circuit breaker. If more than one (1) dispenser power circuit breaker is used, all dispenser power circuit breakers must be installed on the same AC line phase.
- Circuit breakers are supplied by the customer.

Ballast Box Layout

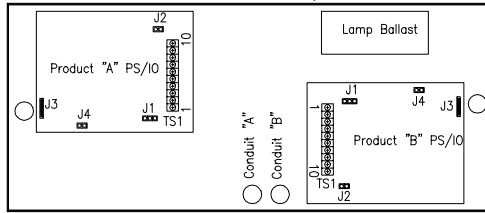

Circuit Breaker Identification  
 CB-1, 2, 3 Dispenser Power \*  
 CB-4 Lamp Power \*\*  
 CB-5, 6 Motor Power \*\*\*

- \* No more than two (2) dispensers per circuit breaker.
- \*\* No more than five (5) dispensers per circuit breaker.
- \*\*\* No more than one (1) pump motor per circuit breaker.

All circuit breakers shown are neutral breaking type.

- Dispenser is factory wired for 115 Vac or 230 Vac operation. This may not be changed in the field.
- N/A
- One (1) motor circuit breaker (CB-5, CB-6, etc.) per pump motor.
- If 115 Vac pumps motors are used, install 115 Vac motor circuit breakers (CB-5, CB-6, etc.), on the AC line phase opposite the AC line phase where the dispenser power circuit breakers (CB-1, 2 & 3) are installed.
- Two (2) Green (GRN) pigtail ground wires on each PS / IO circuit board must be bonded to the ballast box chassis ground via the studs provided.
- N/A
- When "LOW" flow valves are NOT present, connect the Blu (Yel) "HIGH" flow valve wire to the Low flow valve Terminal 3 or 20.

Low flow valves are not present on models

- = Field Connection
- = Factory Connection
- = Terminal Strap

X = Any valid option code

- Product "B" components are not present on models R12X- and C12X- .
- BLU wire color for 115 Vac valves. YEL wire color for 230 Vac valves.
- Connection on single product twin only. Models R24X- and C24X- .
- N/A
- If an intercom system is used, DO NOT run the intercom and pump wires in the same conduit. Otherwise, electrical interference may occur with the intercom system or pump data communications.
- Refer to lamp ballast label for ballast/lamp wiring instructions.
- Install RC/MOV filters across coils and contacts of all submerged pump motor control contactors. See sheet 2 for Bennett Part No.

Electrical Ratings	
Dispenser Power	120 Watts 115 / 230 Vac
Lamp Power	90 Watts 115 / 230 Vac
Main Control Valves	15 Watts 115 / 230 Vac
Remote Output	240 Vac, 30 VA max.
Encoder	30 mA, 5 Vdc
	Intrinsically Safe
Customer Pump Switch	Magnetic Reed Switch
	Intrinsically Safe

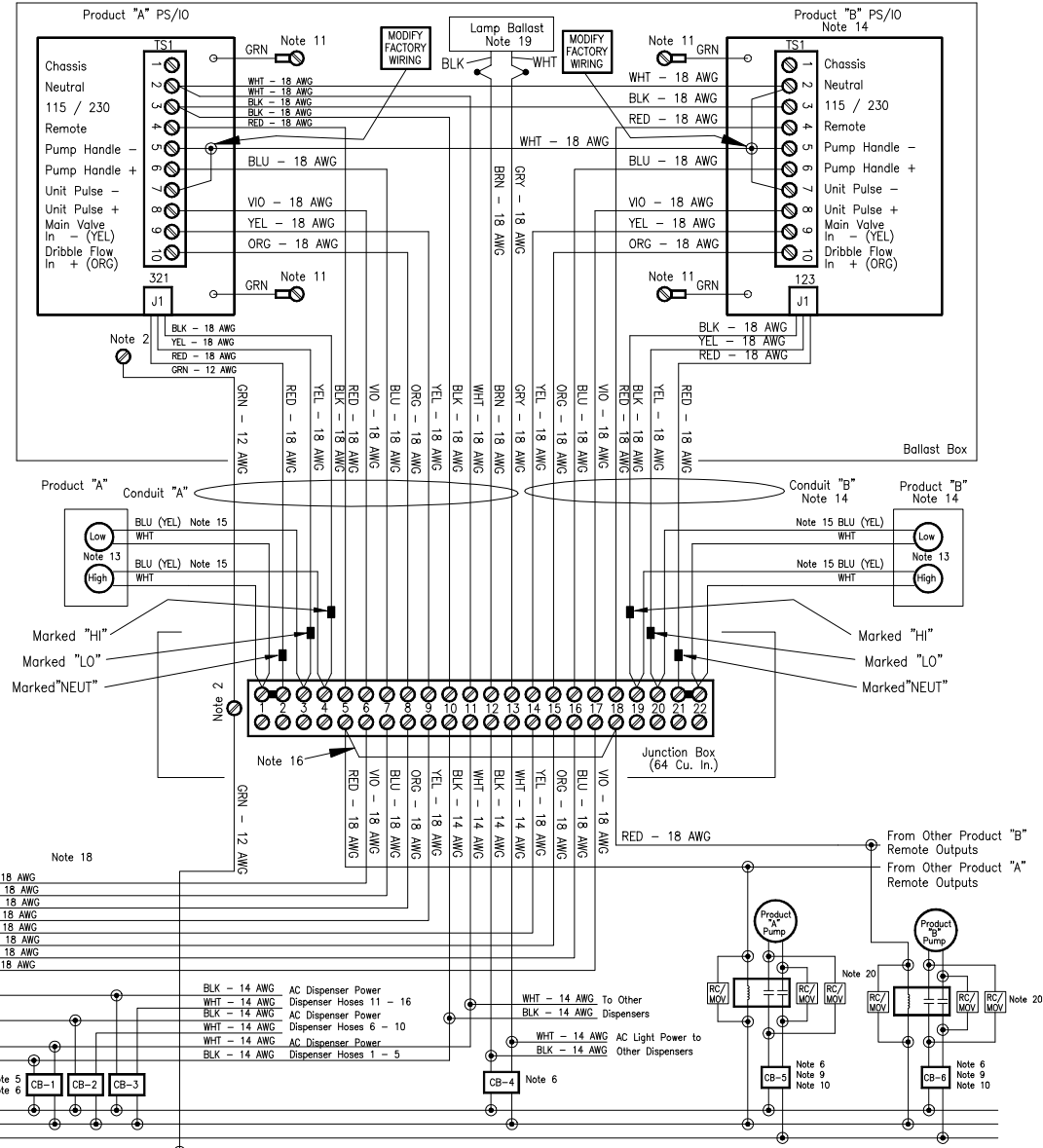

115/230 Vac  
 L1  
 N  
 L2  
 Main Supply