

ⓑ TAP DRILL .66 [16.8]
 M8 X 1.25 TAP
 .58 [14.7] MIN. FULL THD.
 65 % THREAD MIN.
 6 HOLES

⊕ ⌀.015 [0.38] Ⓢ A B Ⓢ

4.12⌀ B.C.
 [104.6⌀]

Ⓐ 63
 ▱ .003
 4X

ⓒ
 ⓓ

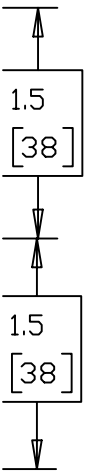
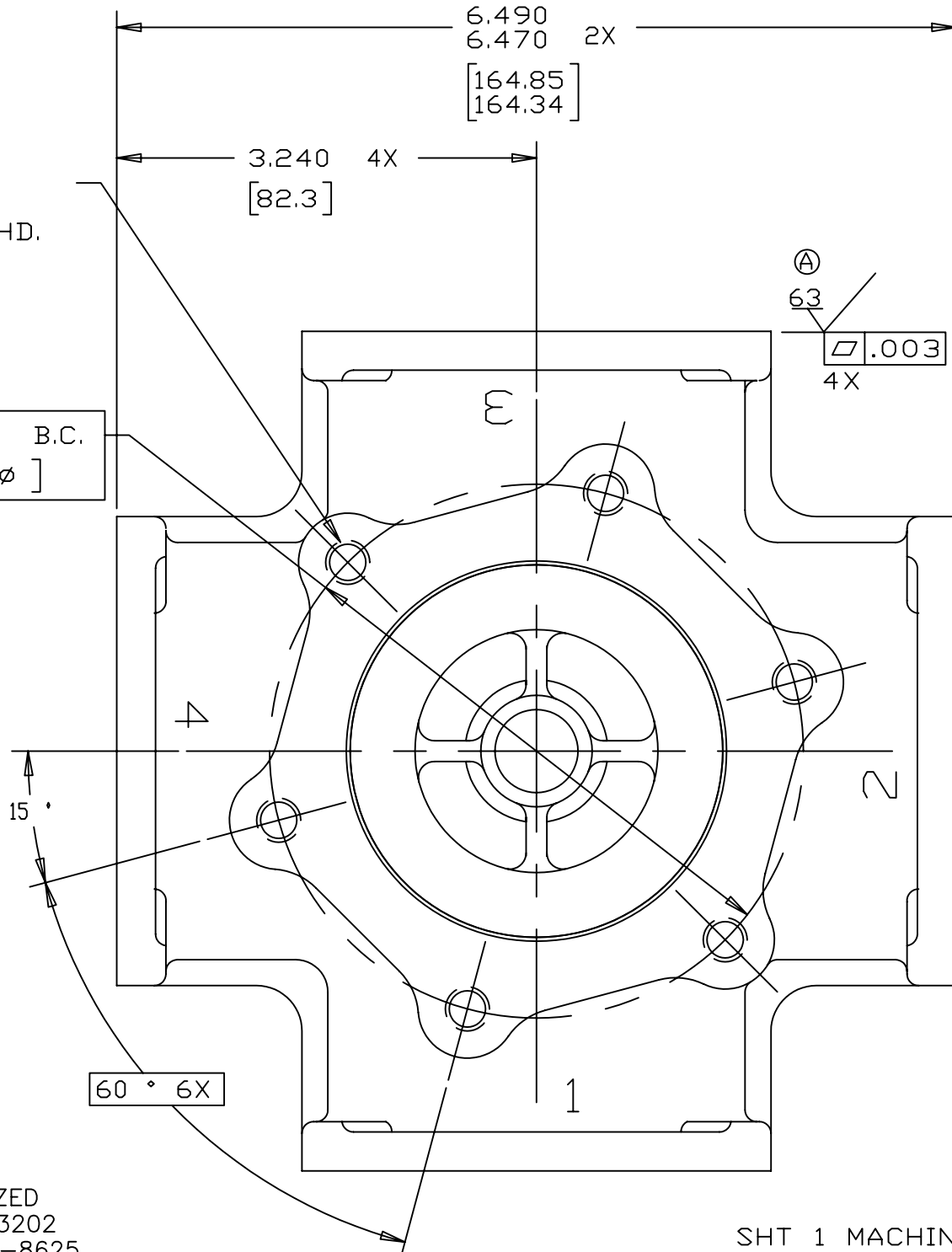

ANODIZE NOTES:
 P/N 103045 TO BE ANODIZED
 MAKE FROM BPC P/N N643202
 BLACK ANODIZE PER MIL-A-8625
 TYPE II, CLASS II.

SHT 1 MACHINING